

KMW

an **ATS** company



Produktion von **N95 Masken**

Wir entwickeln für **SIE** schnell verfügbare Lösungen



Montagelinie N95 Masken

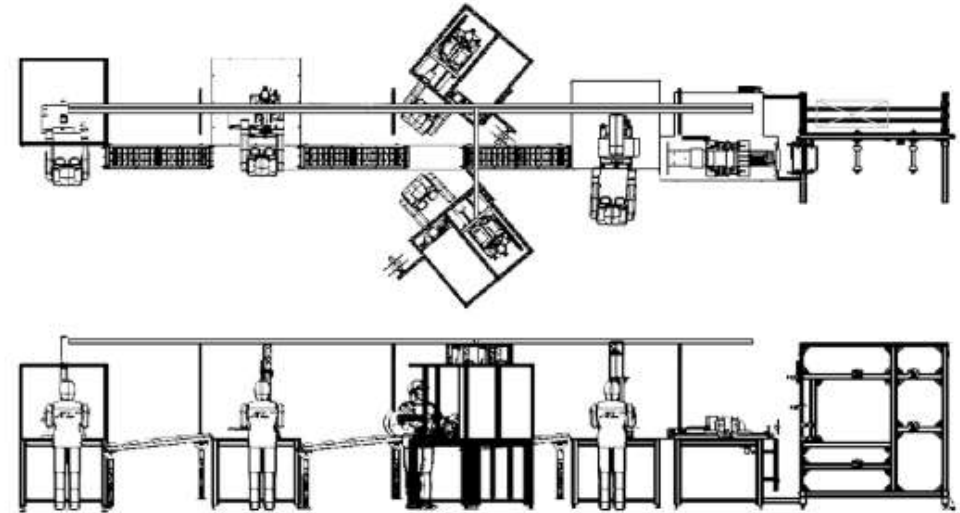

- Taktzeit: **10 Stück / Minute**
- Fläche: **ca. 2m x 14m**

5 Operator + 1 Materialversorger
2m Sicherheitsabstand für Bediener

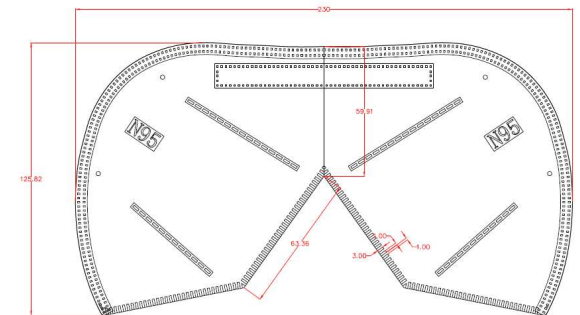

Zuschnitt

Montageablauf

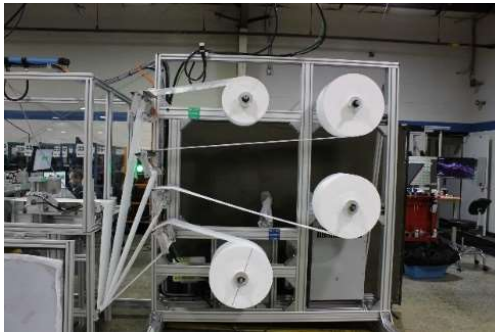

- Materialzuführung von Rollen
- Zuschnitt und verschweißen der 4 Lagen

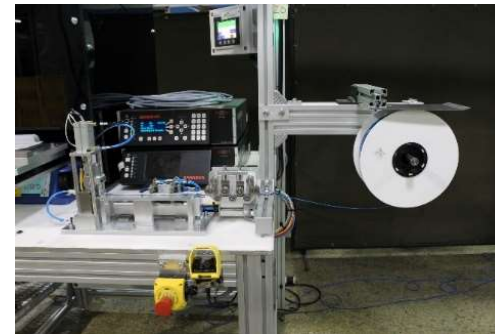
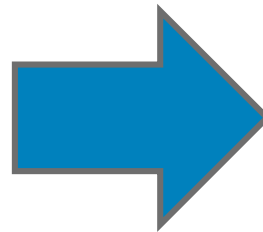

- Nasenklemme auf Maske auflegen
- Verschweißen der Maskenkonturen

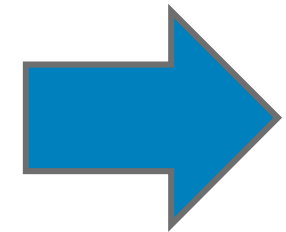

Montageablauf

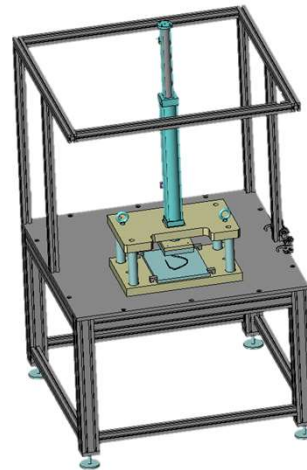

- Maske falten und verschweißen

- Zuschnitt der Maskenkontur

- Fertige Maske

Preise & Konditionen



N 95 - Maskenmontageanlage 490.000 €

wie beschrieben, excl. Mwst, Lieferung und Verpackung

Tragebandmontage 119.900 €

Verpackungsmaschine 19.900 €

Lieferzeit 4 – 8 Wochen

Die tatsächliche Lieferzeit hängt vom Auftragseingangsdatum ab. Die Lieferzeit der integrierten Kaufteile, wie z.B. Ultraschallgeräte, kann z.Z. leider täglich variieren.

Bitte beachten Sie, dass die deutsche Regierung plant, Hersteller von Schutzmasken direkt zu subventionieren. Erkundigen Sie sich daher bitte aktuell, welche Subventionen Ihnen zur Finanzierung dieses Systems evtl. zur Verfügung stehen.

Global Overview

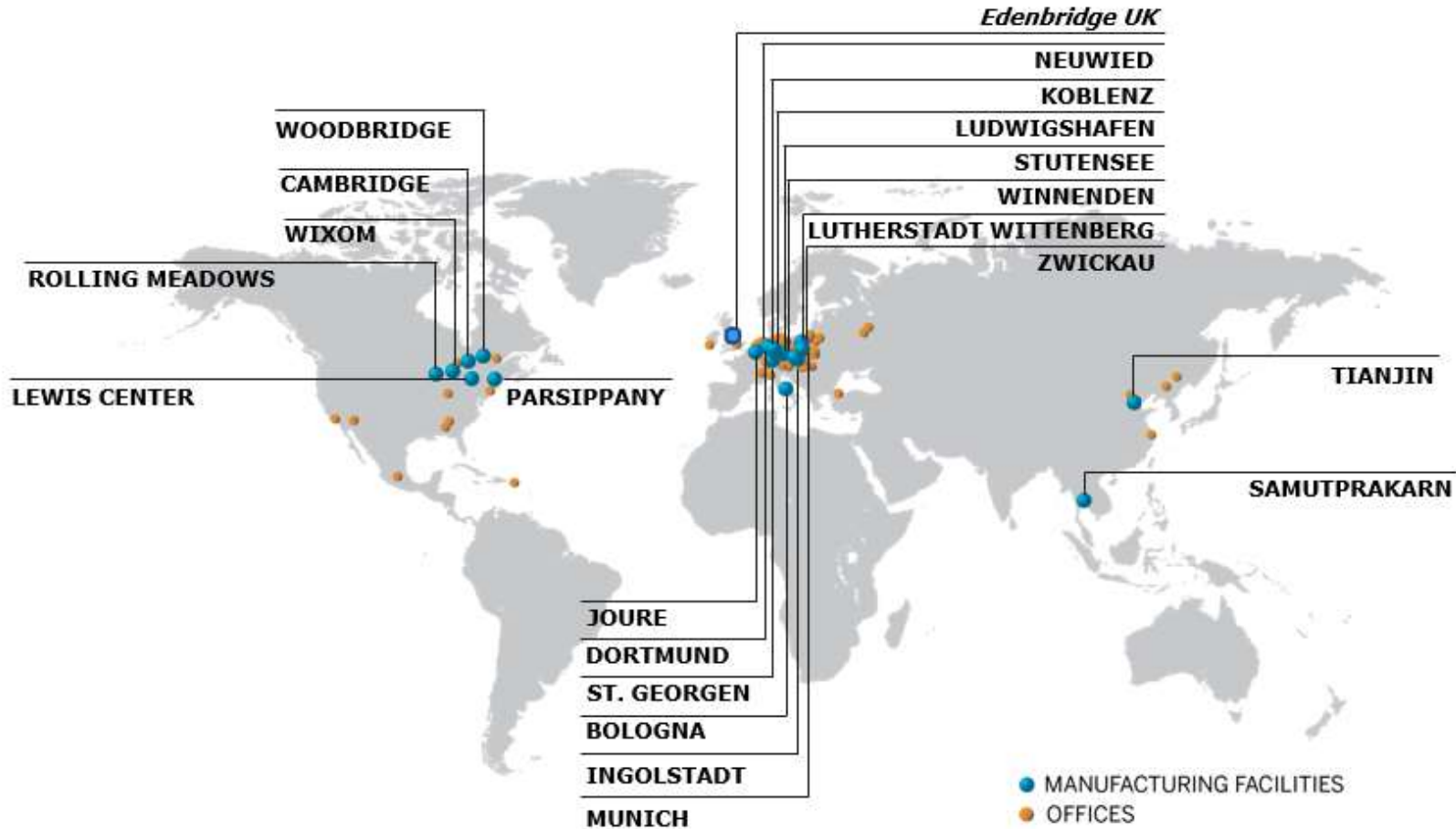

Leistungen



Montageautomatisierung

Teil- und Vollautomatische Montageanlagen
Robotik, Kamera, Performance- und EOL-Test
Schrauben, Pressen, Fetten, Kleben ...
Sauber- und Reinraumfähigkeit



Service

Ersatzteile, Einzelteil- und Prototypenherstellung
Upgrade und Anlagenumbau
Baugruppenherstellung und Kleinserienfertigung
Höchste Präzision - Just in Time

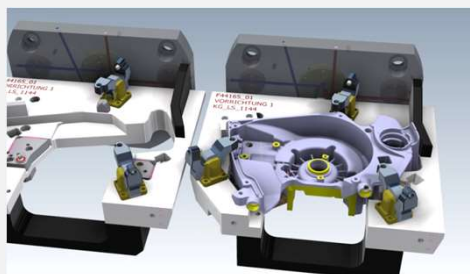

Spannvorrichtungen

Hydraulische Ein- und Mehrfachspannlösungen
Konzeptentwicklung inkl. Beratung
Dokumentierte Genauigkeit
Build to print

Confidential & Proprietary



Project examples

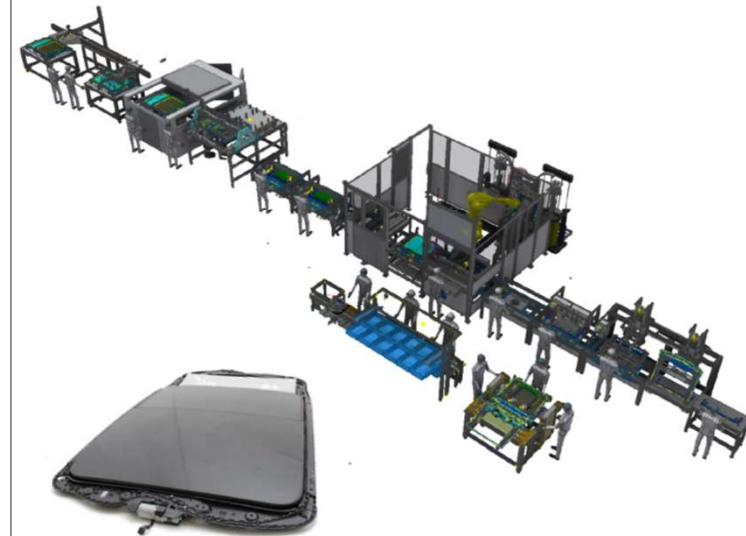
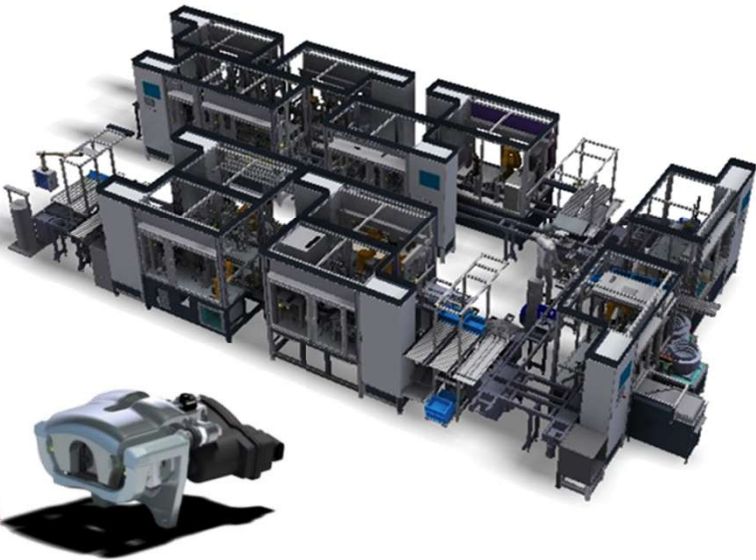
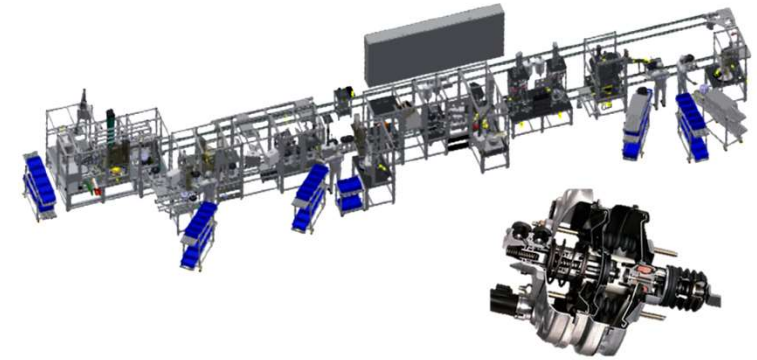

Confidential & Proprietary



Ihr Ansprechpartner im Vertrieb



Assembly & Test - Europe GmbH
Carl-Borgward-Straße 11
56566 Neuwied Germany

E-mail: mhaubrich@atwautomation.com

Handelsregister: HRB 13740, Amtsgericht Montabaur, Geschäftsführer/in:
Udo Panenka, Maria Perrella
An ATS Company (www.atsautomation.com)



Michael Haubrich

Sales Manager
Mobility and Specialty Automation

Mobile: +49 174 3038203
E-mail: mhaubrich@atwautomation.com

Confidential & Proprietary



ATS TM

The logo features the letters 'ATS' in a bold, italicized, sans-serif font. The letters are filled with a dark grey color and have a white outline. The 'A' is a simple block letter, while the 'T' and 'S' have a more complex, stylized design with a horizontal bar and a vertical stem. The 'S' is a continuous, flowing shape. Above the 'T' and 'S' are three parallel blue diagonal stripes, and below the 'A' and 'T' are three parallel blue diagonal stripes. To the right of the letters is the trademark symbol 'TM'.